



EP
Let's grow together

EPT20-15ET2

Electric Pallet Truck 1.5t

- Small size, light service weight, simple operation;
- Energy-saving and environmental, lower cost;
- More convenient for maintenance.

EP EQUIPMENT CO.,LTD
www.paleciaki.info



Electric Pallet Truck 1.5t

EPT20-15ET2

Distinguishing mark				
1.1	Manufacturer			EP
1.2	Model designation			EPT20-15ET2
1.3	Drive unit			Electrics
1.4	Operator type			pedestrian
1.5	rated capacity	Q	kg	1500
1.6	Load center distance	c	mm	600
1.8	Load distance	x	mm	883/946
1.9	Wheelbase	y	mm	1202/1261
Weight				
2.1	Service weight (include battery)		kg	195
2.2	Axle loading, laden driving side/loading side		kg	567/1128
2.3	Axle loading, unladen driving side/loading side		kg	155/40
Types, Chassis				
3.1	Tyre type driving wheels/loading wheels			PU/ PU
3.2	Tyre size, driving wheels (diameter×width)		mm	Φ210x70
3.3	Tyre size, loading wheels (diameter×width)		mm	2x Φ78x60 (Φ78x88)
3.4	Tyre size, caster wheels (diameter×width)		mm	—
3.5	Wheels, number driving, caster/loading (x=drive wheels)		mm	1x /4 (1x /2)
3.6	Track width, front, driving side	b ₁₀	mm	448
3.7	Track width, rear, loading side	b ₁₁	mm	410 (535)
Dimensions				
4.4	Lift height	h ₃	mm	115
4.9	Height drawbar in driving position min./max.	h ₁₄	mm	750/1170
4.15	Lowered height	h ₁₃	mm	80
4.19	Overall length	l ₁	mm	1638
4.20	Length to face of forks	l ₂	mm	488
4.21	Overall width	b ₁ / b ₂	mm	560 (685)
4.22	Fork dimensions	s/ e/ l	mm	50/150/1150
4.25	Outside width of the forks	b ₅	mm	560 (685)
4.32	Ground clearance, center of wheelbase	m ₂	mm	30
4.34.1	Aisle width for pallets 1000 × 1200 crossways	Ast	mm	1739
4.34.2	Aisle width for pallets 800 × 1200 lengthways	Ast	mm	1939
4.35	Turning radius	Wa	mm	1485
Performance data				
5.1	Travel speed, laden/ unladen	km/ h	km/h	4/4.5
5.2	Lifting speed, laden/ unladen		m/ s	0.027/0.038
5.3	Lowering speed, laden/ unladen		m/ s	0.059/0.039
5.8	Max. gradeability, laden/unladen		%	5/16
5.10	Service brake type			Electromagnetic
Electric-engine				
6.1	Drive motor rating S2 60 min		kW	0.65
6.2	Lift motor rating at S3 15%		kW	0.84
6.3	The maximum allowed size battery		mm	265*185*215
6.4	Battery voltage/nominal capacity K20		V/ Ah	24/55
6.5	Battery weight		kg	22.5x2
Addition data				
8.1	Type of drive control			DC
10.5	Steering type			Mechanical
10.7	Sound pressure level at the driver's ear		dB (A)	74

If there are improvements of technical parameters or configurations, no further notice will be given.
The diagram shown may contain non-standard configurations.

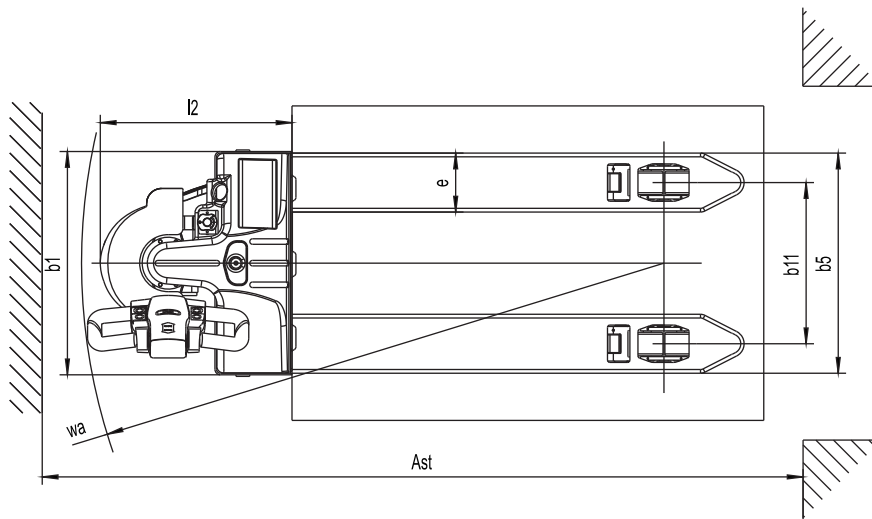
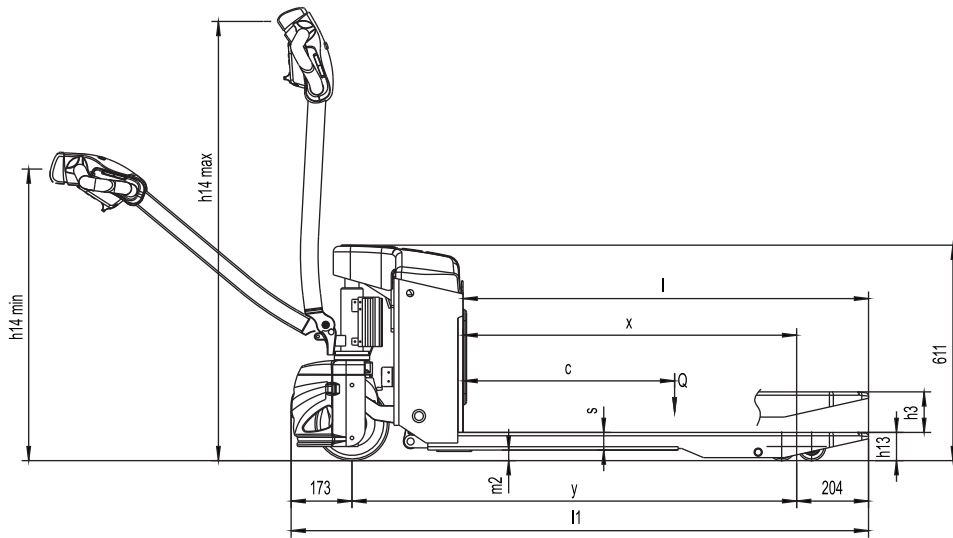

Option

Options	type	EPT20-15ET2
Fork length		○700 ~ 1500
Fork width		○520/600
Single load wheel	ground clearance 75mm	○
Driving wheel		○PU wheel with Pattern
Balance wheel		○
Battery capacity		○85AH
Vertical handler working		○
In and out of the tray guide wheel		○
Special backrest		○1220mm (48in) /1520mm (60in)
Note: Fork length < 1400, capacity 1.5T; Fork length ≥1400, capacity 1.0 T		
Note: ● standard ○ option — NA		