

V2007.1



EPL154

Electric Pallet Truck 1.5T

- Optimized structure, easy operation
- New design of plug-in&out battery
- Rigorous design, stable operation
- Reliable drive system

EP EQUIPMENT CO.,LTD
www.paleciaki.info

FEATURE

■ Optimized structure, easy operation

The metal protective cover of battery can be flipped over, which can effectively protect the battery; The battery has simple cover with two combination modes, it can prevent the battery from plugging and unplugging at will.



■ New design of plug-in&out battery

The truck uses on-board chargers and it can be charged whenever and wherever you want.

The truck can be equipped with Li-Ion batteries of 30Ah, which can meet different kinds of working condition . Li-ion battery developed by EP is equipped with BMS(battery management system), which is more convenient to use.



■ Rigorous design, stable operation

It is equipped with industrial floating universal wheels as standard and offers great passability.



■ Reliable drive system

EPL154 adopts the same mature and reliable drive system of EPT20-15ET, and its gradeability can reach 10%.



Electric Pallet Truck 1.5T

EPL154

Distinguishing mark				
1.1	Manufacturer			EP
1.2	Model designation			EPL154
1.3	Drive unit			Battery
1.4	Operator type			Pedestrian
1.5	rated capacity	Q	kg	1500
1.6	Load center distance	c	mm	600
1.8	Load distance	x	mm	940(875)
1.9	Wheelbase	y	mm	1200(1135)
Weight				
2.1	Service weight (include battery)		kg	160
2.2	Axle loading, laden driving side/loading side		kg	555/1105
2.3	Axle loading, unladen driving side/loading side		kg	130/30
Types,Chassis				
3.1	Tyre type driving wheels/loading wheels			PU/PU
3.2	Tyre size, driving wheels (diameterxwidth)		mm	Φ210x70
3.3	Tyre size, loading wheels (diameterxwidth)		mm	Φ80x60(Φ74x88)
3.4	Tyre size, caster wheels (diameterxwidth)		mm	Φ74x30
3.5	Wheels, number driving, caster/loading (x=drive wheels)		mm	1x, 2/4(1x, 2/2)
3.6	Track width, front,driving side	b10	mm	450
3.7	Track width,rear,loading side	b11	mm	390/(535)
Dimensions				
4.4	Lift height	h3	mm	115
4.9	Height drawbar in driving position min./max.	h14	mm	650/1170
4.15	Lowered height	h13	mm	80
4.19	Overall length	l1	mm	1550
4.20	Length to face of forks	l2	mm	400
4.21	Overall width	b1/ b2	mm	610(695)
4.22	Fork dimensions	s/ e/ l	mm	50x150x1150
4.25	Distance between fork-arms	b5	mm	540(685)
4.32	Ground clearance, center of wheelbase	m2	mm	30
4.34.1	Aisle width for pallets 1000 × 1200 crossways	Ast	mm	2094
4.34.2	Aisle width for pallets 800 × 1200 lengthways	Ast	mm	2146
4.35	Turning radius	Wa	mm	1330
Performance data				
5.1	Travel speed, laden/ unladen	km/ h	km/h	4.5/5
5.2	Lifting speed, laden/ unladen		m/ s	0.028/0.031
5.3	Lowering speed, laden/ unladen		m/ s	0.068/0.043
5.8	Max. gradeability, laden/unladen		%	6\16
5.10	Service brake type			electric
Electric-engine				
6.1	Drive motor rating S2 60 min		kW	0.75
6.2	Lift motor rating at S3 15%		kW	0.8
6.3	The maximum allowed size battery		mm	270*110*400
6.4	Battery voltage/nominal capacity K5		V/ Ah	24/30
6.5	Battery weight		kg	10
Addition data				
8.1	Type of drive control			DC
10.5	Steering type			mechanical
10.7	Sound pressure level at the driver's ear		dB (A)	<74

If there are improvements of technical parameters or configurations, no further notice will be given.
The diagram shown may contain non-standard configurations.

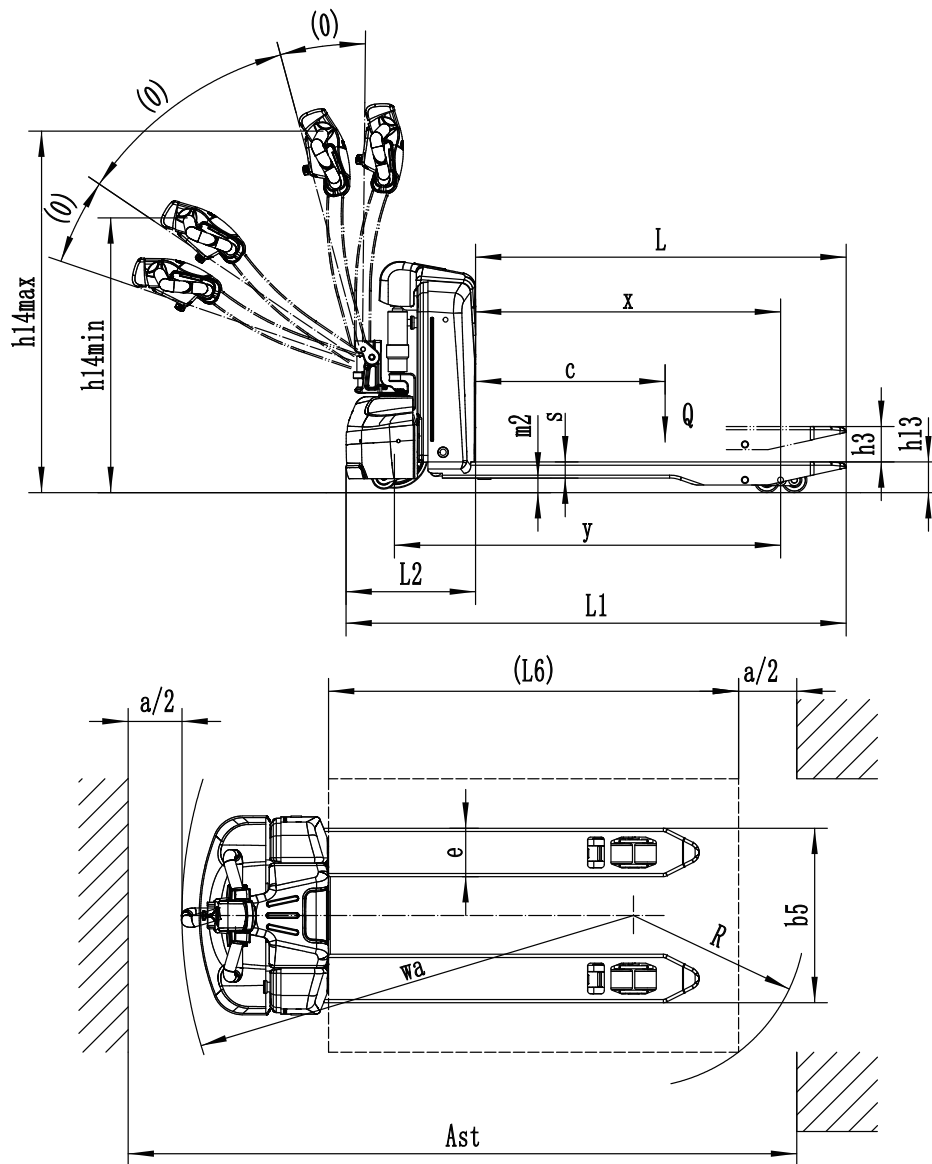

Option:

Optional items		EPL154
1	Fork length	1150/900/1000/1220/1350/1500/2000
2	Fork width	540/685
8	Double load wheel	●
9	Single load wheel	○
10	Driving wheel	-
11	Balance wheel	○
15	cold storage	-
17	Battery indicator with hour meter	●
18	Battery indicator without hour meter	-
19	Battery capacity	-
20	Lateral change battery	-
22	Water auto-filling system	-
25	Vertical handler working	●
31	half speed function in turning	-
32	Guard arm	-
33	Fork lowered height	-
34	Special backrest	○

Note: ● standard ○ option — NA