



F Series - F4 201

Li-Ion Pallet Truck 2.0T

- Power and capacity upgrade for productivity boost
- Plug in&out Li-ion batteries maximize flexibility
- Parts compatibility lowering operation costs
- Platform-based design to maximize competitive advantage in the market
- Cost-saving operations throughout the distribution cycle

LI-ION
TECHNOLOGY

EP EQUIPMENT CO.,LTD
www.ep-equipment.com

Li-Ion Pallet Truck 2.0T

F Series - F4 201

| | | | | | |
|---------------------|----------------------|---|--------------------------------|-------|--------------------|
| Distinguishing mark | 1.1 | Manufacturer | | | EP |
| | 1.2 | Model designation | | | F4 201 |
| | 1.3 | Drive | | | Electric |
| | 1.4 | Operator type | | | Pedestrian |
| | 1.5 | Load capacity | Q | kg | 2000 |
| | 1.6 | Load center distance | c | mm | 600 |
| | 1.8 | Load distance, centre of drive axle to fork | x | mm | 950 |
| | 1.9 | Wheelbase | y | mm | 1180 |
| | Service weight | 2.1 | Service weight | | kg |
| 2.2 | | Axle loading, laden front/rear | | kg | 620/1520 |
| 2.3 | | Axle loading, unladen front/rear | | kg | 100/40 |
| Tyres/chassis | 3.1 | Tyre type | | | Polyurethane |
| | 3.2 | Tyre size, front | | | 210mm×70mm |
| | 3.3 | Tyre size, rear | | | 80mm×60mm |
| | 3.4 | Additional wheels (castor wheels) | | mm | 74mm×30mm |
| | 3.5 | Wheels, number front/rear (x=drive wheels) | | mm | 1x, —/4 |
| | 3.6.1 | Tread width, front | b ₁₀ | mm | — |
| | 3.7.1 | Tread width, rear | b ₁₁ | mm | 410 (535) |
| Dimensions | 4.4 | Lift height | h ₃ | mm | 105 |
| | 4.9 | Height of tiller handle in drive position min./max. | h ₁₄ | mm | 750/1190 |
| | 4.15 | Lowered height | h ₁₃ | mm | 85 |
| | 4.19 | Overall length | l ₁ | mm | 1550 |
| | 4.20 | Length to face of forks | l ₂ | mm | 400 |
| | 4.21 | Overall width | b ₁ /b ₂ | mm | 590 (695) |
| | 4.22 | Fork dimensions | s×e×l | mm | 50X150X1150 |
| | 4.25 | Distance between fork-arms | b ₅ | mm | 560 (685) |
| | 4.32 | Ground clearance, center of wheelbase | m ₂ | mm | 30 |
| | 4.34.1 | Aisle width for pallets 1000×1200 crossways | Ast | mm | 2160 |
| | 4.34.2 | Aisle width for pallets 800×1200 lengthways | Ast | mm | 2025 |
| | 4.35 | Turning radius | Wa | mm | 1360 |
| Performance data | 5.1 | Travel speed, laden/unladen | | km/h | 4.5/5 |
| | 5.2 | Lifting speed, laden/unladen | | m/s | 0.016/0.020 |
| | 5.3 | Lowering speed, laden/unladen | | m/s | 0.058/0.046 |
| | 5.8 | Max. gradeability, laden/unladen | | % | 8/16 |
| | 5.10 | Service brake | | | Electromagnetic |
| Electric-engine | 6.1 | Drive motor rating S2 60 min | | kW | 0.9 |
| | 6.2 | Lift motor rating at S3 15% | | kW | 0.7 |
| | 6.4 | Battery voltage/nominal capacity | | V/Ah | 48/20 |
| | 6.5 | Battery weight | | kg | 10 |
| | 6.6 | Energy consumption according to DIN EN 16796 | | kWh/h | 0.18 ¹⁾ |
| | 6.7 | Turnover output according to VDI 2198 | | t/h | 88 |
| | 6.8 | Turnover efficiency according to VDI 2198 | | t/kWh | 473.12 |
| | Drive/lift mechanism | 8.1 | Type of drive control | | |
| 10.5 | | Steering design | | | Mechanical |
| 10.7 | | Sound pressure level at the driver's ear | | dB(A) | 74 |
| 15.1 | | Charger output current | | A | — |

If there are improvements of technical parameters or configurations, no further notice will be given.
The diagram shown may contain non-standard configurations.

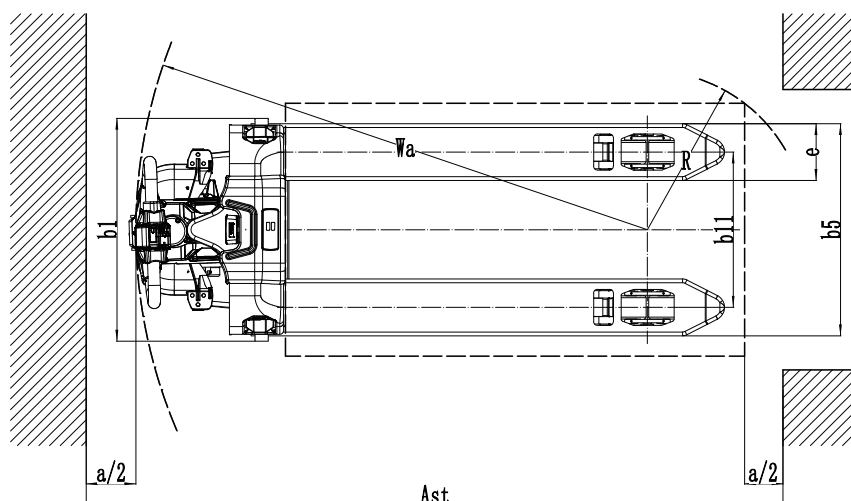
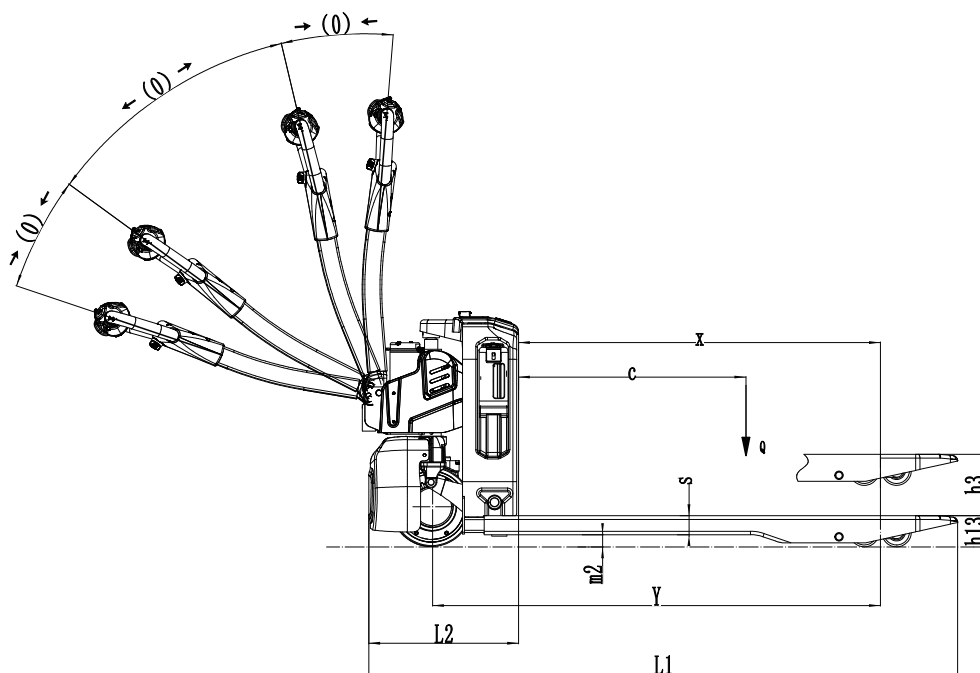

Option:

| No. | Optional items | F4 201 |
|------|----------------------------|--|
| 1.1 | Fork dimension | ●1150*560○900*560○1000*560○1220*560○1350*560○1500*560○900*685 ○1000*685○1150*685○1220*685○1350*685○1500*685 |
| 1.3 | Fork lowered height | ●80 |
| 1.6 | Drive cover off the ground | ●55mm |
| 2.1 | Load wheel type | ●Double○Single |
| 2.2 | Load wheel material | ●PU |
| 2.3 | Drive wheel material | ●PU |
| 2.7 | Battery capacity | ●24V/20AH×2 ○24V/20AH×3 ○24V/20AH×4 |
| 2.8 | Charger | ●24V-5A external charger X2 ○24V-10A external charger X2 |
| 2.9 | Battery indicator | ●Without time |
| 2.16 | handle head type | ●Square-tube tiller head |
| 3.3 | Castor wheels | ●No○Yes and not customized |
| 3.12 | Buzzer | ●Yes and not customized |
| 3.16 | Turtle speed | ●Yes and not customized |

Note: ●Standard ○ Optional - Inconformity